



Installation Manual for Single-glass



Jiangsu Green Energy Power Technology Co., Ltd.

Directory

1. Introduction	3
2. Safety Precautions	3
2.1 General safety	3
2.2 Operational safety	4
2.3 Installation safety	5
3. Installation	5
3.1 General Instructions	5
3.2 Mechanical installation	6
3.2.1 Bolt installation	7
3.2.2 Fixture installation	9
3.3 Electrical installation	10
3.3.1 Module Wiring	11
3.3.2 Module grounding	11
4. The inverter prevents the PID effect of the components	12
5. Maintenance	12
6. Electrical parameters	13

1. Introduction

Thank you for choosing the GEP modules. This installation manual is applicable to the operation and maintenance of the series of modules produced by our company.

Please read this manual carefully before you operate and install the modules. It contains basic information on mechanical and electrical installation, as well as important safety information that you must understand. If a module is not operated in accordance with all the steps in this manual, the warranty and guarantee claims of that module shall be invalid. We update the information in this manual without further notice.

The installation, operation and maintenance of modules require a high level of technical ability and experience, so qualified personnel with the relevant skills and basic knowledge of electricity, electronics and mechanics are needed.

2. Safety Precautions

Improper operation may cause damage, so the installation and commissioning of solar photovoltaic systems may require specialized skills and knowledge. Installers must read and understand all the safety measures described in this manual before installation. The following safety instructions and warnings are an important part of this manual and are instructive. If you have any questions, please contact our customer service department for further assistance.

2.1 General safety

When you attempt to install, wire, operate and maintain modules, please ensure that you fully understand the information described in this manual.

- Before installation, do not place the modules outdoors or in a damp environment to prevent damage to the packaging box due to rain;
- To avoid the risk of injury or electric shock, operators who do not meet the standards or personnel who are not familiar with photovoltaic modules and photovoltaic systems are not allowed to touch damaged modules;
- The modules application level is in accordance with IEC 61730-1 2023: Class II;
- If the modules are installed on the roof of A building, the roof needs to be fireproof. If necessary, external fire-resistant materials should be used for isolation. The fire resistance rating of single-glass modules is Class C, and that of double-glass modules is Class A;
- Mechanical stability checks must be conducted before the installation of modules. Damaged solar modules (such as broken glass or damaged backsheet layers) should not be used, as this may lead to serious consequences that endanger health and life;
- When installing on the roof or ground, some appropriate safety equipment should be used to

avoid possible safety hazards. Note that when modules are installed on some roofs, additional fire protection measures may be required. Construction should be carried out in accordance with local building fire protection regulations;

- Electricity is generated when modules are exposed to sunlight. Even a single solar module can generate sufficient voltage and current, which may cause electric shock or burns if safety measures are not in place. The risk of electric shock increases when modules are connected in series or parallel;
- It is best not to install modules in areas where there are flammable objects, gases or moisture around;
- The artificially concentrated sunlight must not be directed onto the module panel;
- Uninstalled modules should not be placed horizontally to prevent the accumulation of dirt, water and frost;
- Do not allow water to remain on the module glass surface for a long time, as this may cause permanent damage to the glass (such as white spots);
- Do not clean the surface of the modules with chemical agents.

2.2 Operational safety

- The modules must not be placed vertically or unfixedly at will;
- The module frame cannot be drilled, nailed or welded onto one contact surface, as this will reduce the strength of the frame and cause corrosion to it;
- Do not scratch the anodic oxide film on the module frame, as this may cause the frame to be corroded or reduce its strength;
- Do not place any heavy objects on the modules;
- Do not step on or walk on the modules. If the glass breaks, there is a risk of injury or electric shock;
- To avoid the risk of electric leakage caused by damage to the junction box, do not strike or collide with the junction box, and do not pull the cable;
- To prevent the back plate of the module from being damaged, do not scratch or strike the back of the module;
- The drainage holes on the modules must not be covered;
- One side of the module cannot be lifted only. It is necessary to hold the long side of the module with both hands to move it;
- Do not touch the modules in damp conditions unless you are wearing appropriate personal protective equipment (PPE). Work should only be carried out in a dry environment using dry tools;

2.3 Installation Safety

- Before installation, always keep the modules in the packaging box;
- During the installation process, protective equipment such as safety helmets, insulating gloves and safety shoes must be worn all the time;
- The glass of the module cannot be used for installation after it breaks;
- Do not carry out installation work in rainy, snowy or windy conditions;
- Do not perform any installation work if the cable connector is wet;
- When installing and debugging photovoltaic systems, it is not allowed to wear metal rings, watch straps or other metal objects;
- The modules need to be aligned in the same direction (both horizontally and vertically). In the case of angular deviation, a separate inverter needs to be designed;
- When installing in the sun, whether the modules are connected to the photovoltaic system or disconnected, do not touch the junction box and cable connectors with bare hands;
- The cable plug should be correctly connected, and all connections should be checked before being connected to the system circuit;
- If the photovoltaic system is connected to a workload, do not unplug the cable connector;
- The connected cables should be kept away from direct sunlight, as direct sunlight can cause the insulation layer of the cables to age rapidly;
- Use light-resistant nylon cable ties or other management tools to bind interconnected cables, as sagging cables may lead to potentially serious consequences such as electric shock;
- All other modules in the photovoltaic system, such as cables, cable connectors, frequency converters, charging regulators, batteries, etc., must comply with the safety regulations and management system;
- Snow accumulation may cause deformation of the module frames. Appropriate measures should be taken to reduce any potential damage to the modules.

3. Installation

3.1 General Description

Installation instructions described in this manual must be followed to ensure compliance with all applicable local standards and building regulations.

The recommended weather conditions for installing the modules are:

- a) Humidity : <85% relative humidity
- b) Ambient air temperature range: -40°C 至 +40°C
- c) Working temperature: -40°C 至 + 70°C

- Under normal circumstances, modules should be installed in the location that can receive the most sunlight throughout the year. In the Northern Hemisphere, it is recommended that modules be placed facing south. In the Southern Hemisphere, it is recommended that modules be placed facing north. If the tilt Angle of the module deviates from the south (or north) direction by 30 degrees, the power output of the module will be lost by approximately 10% to 15%. If the tilt Angle of the module deviates from the south (or north) direction by 60 degrees, the power output of the module will be lost by approximately 20% to 30%. Determine the optimal azimuth for module installation by referring to the longitude and latitude of the installation site;

- The maximum altitude of the module installation site $\leq 2000\text{m}$.

- When choosing a site, avoid trees, buildings or other obstacles that may cast shadows on the modules. Shadows can lead to a loss of power output from modules. Even though bypass diodes have been installed on the modules, shadows still affect the optimal performance and operational safety of the modules. It is not recommended to operate under permanent shade conditions;

- The modules can be installed on land 50 to 500 meters away from the seaside. However, when installing the modules within this distance range, the connectors need to be protected or dust plugs added. After removing the dust plugs, they must be connected immediately, and other anti-rust measures should be taken to prevent the related parts from rusting;

- In off-grid photovoltaic systems with batteries, the tilt Angle of the modules installed on buildings that are used for a long time needs to be adjusted in combination with seasonal loads and sunlight to optimize the performance of the modules. In grid-connected systems, the tilt Angle of modules installed on buildings that have been in long-term use needs to be adjusted to maximize the annual power generation of the modules;

- The modules should be fixed and clamped in the appropriate position according to the design of the photovoltaic installation structure. The installation structure must be made of anti-corrosion materials and capable of withstanding the required load.

3.2 Mechanical Installation

The modules can be installed in various places by using different installation mechanisms and methods. The frame should have sufficient strength to achieve the required span for installation. Usually, modules can be installed using bolt holes or fixtures. When installing with fixtures, the fixtures (middle fixtures and end fixtures) must be designed according to the modules, and the minimum dimensions must be consistent with the instructions below and the provided drawings. The fixtures should be made of aluminum alloy, stainless steel or other suitable waterproof and anti-corrosion materials. In addition, the fixture should not exceed the

width of the frame to avoid casting shadows and module damage. If the fixture designed by the customer or the third-party installation structure is inappropriate or the performance does not meet the requirements (such as material, strength, etc.) during installation, the warranty of the installed module will be invalidated. In addition, fixture installation is regarded as equivalent to installing bolts, so the use of bolt installation under the same conditions is also recognized. To ensure sufficient ventilation, when installing the modules, a minimum gap of 50mm must be left between the module frame and the roof panel/floor.

Please carefully review the instructions and drawings below. Inconsistency between the installation modules and the operation guide may render your warranty invalid.

3.2.1 Bolt installation

Insert four 8mm (M8) stainless steel bolts through the existing 14×9mm installation holes on the module frame, and then through the holes of the support frame. Put on the stainless steel gasket, stainless steel spring washer and 8mm (M8) stainless steel nut, and tighten them. The tightening torque we recommend is 15 to 20N.m. For detailed installation methods, please refer to Figures 1 and 2.

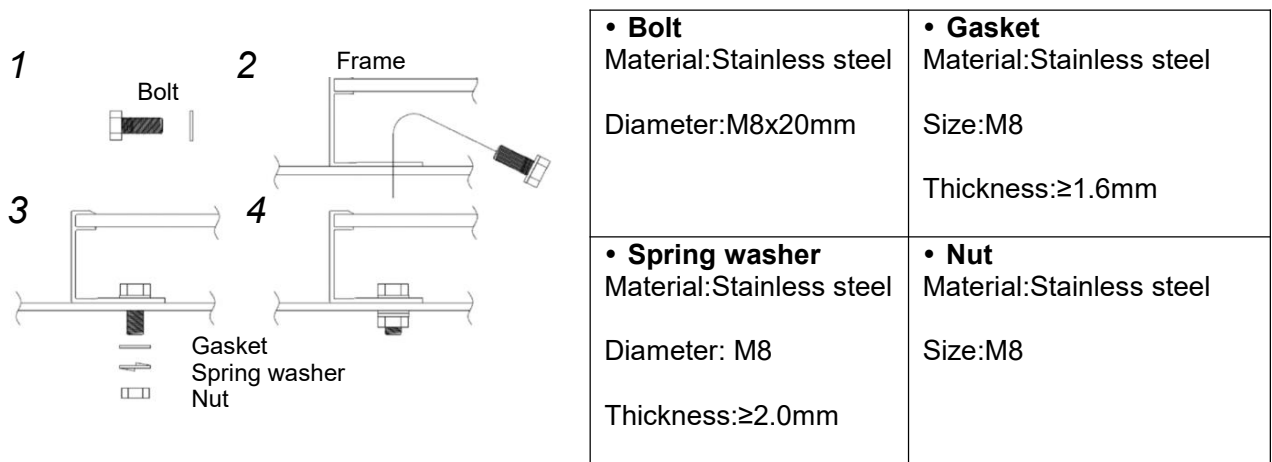

Figures 1:Bolt fixation

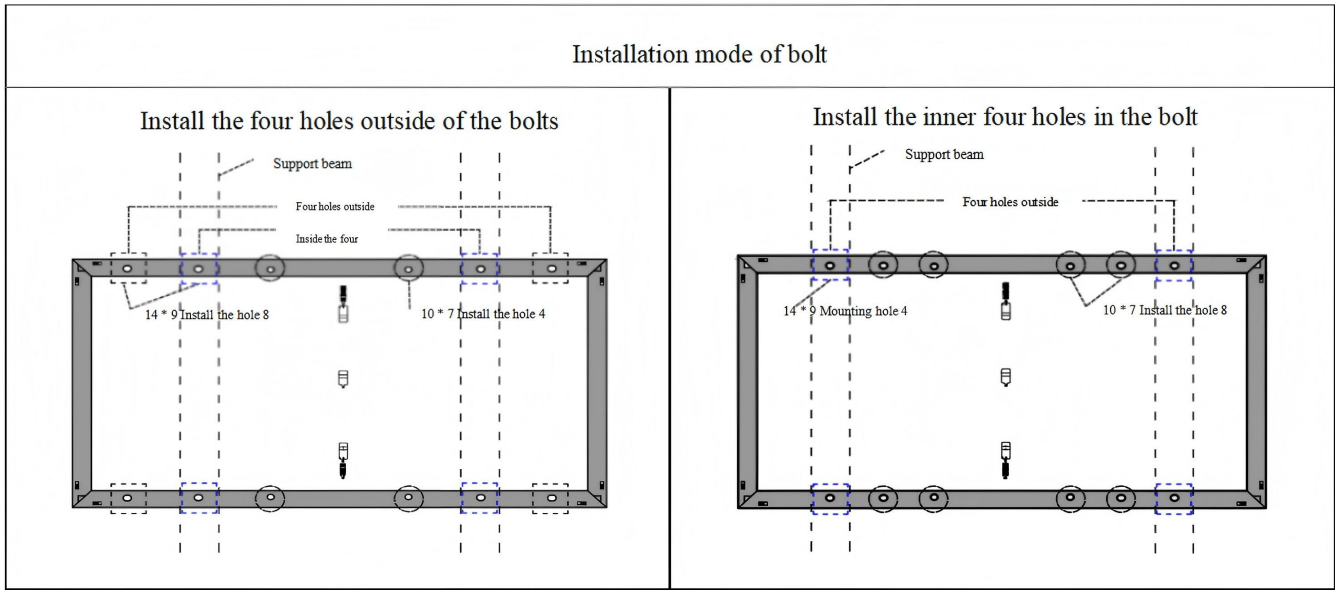

Figure 2: Bolt-fixed modules

Model	Four holes are installed inside the bolt (Maximum test load pa)	The bolts are installed with four outer holes (Maximum test load pa)
Applicable to all modules	+2400/-2400	+5400/-2400

3.2.2 Fixture installation

modules can be installed in various applications, using multiple installation structures and fixation methods. The structure should have sufficient strength to achieve an installation span. Usually, modules can be installed using frame fixtures. When installing with fixtures, the fixtures (middle clamps and end clamps) must be designed in accordance with the following instructions and the provided drawings for the modules and have the minimum dimensions. The fixture should be made of aluminium, stainless steel or other appropriate weatherproof and anti-corrosion materials. In addition, the fixture should be located within the coverage width of the frame to avoid obstruction and module damage. If the fixture designed by the customer or the third-party installation structure is improper or insufficient in terms of performance (material, strength, etc.) or installation, the module warranty will be invalid. To provide sufficient ventilation, the modules must be installed with a gap of at least 50mm between the bottom of the frame and the roof panel/ground surface.

Please carefully review the following instructions and drawings. Failure to install modules in accordance with these instructions may render your warranty invalid.

Fixture installation: Use fixtures that will not deform due to wind or snow loads to firmly fix the modules to the installation structure. Please note that the module can only use the fixture in the allowed fixture area on the long side of the frame. Do not use the fixture on the short side of the frame. Ensure that the fixture does not overlap the glass or block the surface of the module, and that the minimum contact surface on the module frame is 50mm. For detailed explanations, please refer to the following drawings and diagrams. The torque of the M8 bolt is 20N • m.

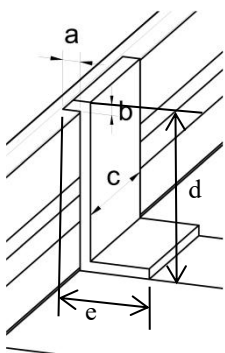

Material: Anodized aluminum 6063-T5 or equivalent material

Short clamp (for two installation rails)	a: Overlap	b: Thickness	c: Width	d: Height	e: Length
For 35mm frames	9.0mm	3.5mm	60mm	38.5mm	36mm
For 30mm frames	9.0mm	3.5mm	60mm	33.5mm	36mm

A module with two installation rails

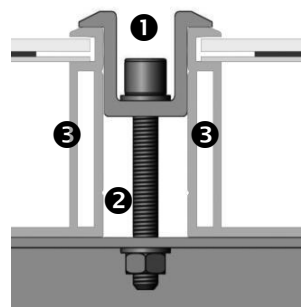
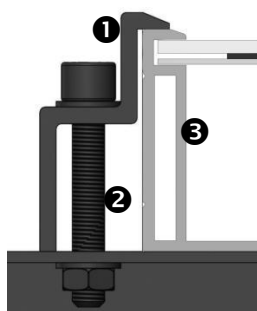

- ❶ Fixed bracket
- ❷ Fastener
- ❸ Frame

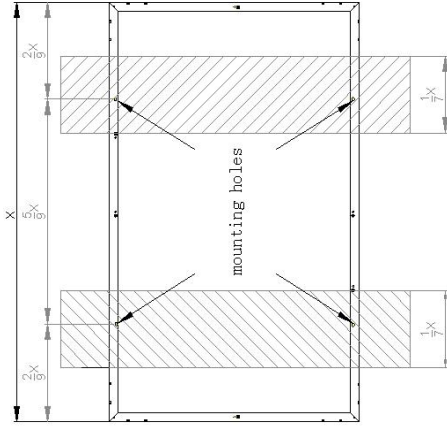
Model	Front 5400pa (safety factor 1.5) Back 2400pa (safety factor 1.5)
Applicable to all modules	 <p>Note: X represents the length of the module, and the fixture installation position is on the border of the shaded area in the figure.</p>

3.3 Electrical Installation

The modules can be connected in series or parallel to achieve the required output voltage. In a combined circuit, only modules of the same model can be used. All relevant electrical performance parameters on the module nameplate should be detailed and pasted on the back of the module. The module specifications refer to Chapter 7 of this manual.

Under normal circumstances, photovoltaic modules may generate more current and voltage than under standard test conditions. Therefore, when determining the rated power of the module, the rated current of the conductor, the size of the fuse and the size of the controller connected to the PV output terminal, the values of ISC (short-circuit current) and VOC (open-circuit voltage) should be multiplied by 1.25.

3.3.1 Module Wiring

Each module is equipped with two 4mm² thick UV-resistant interconnection cables, and the end of each cable is connected to a cable connector compatible with MC4. The positive terminal (+) has a male connector, while the female connector is equipped with a negative terminal (-). Please refer to the wiring method in Figure 3.

When the modules are connected to the battery or other modules, it is essential to pay attention to the correctness of the polarity of the cable connection to ensure the normal operation of the system. If the modules are not connected correctly, the bypass diode will be burned out.

For series or parallel connections, photovoltaic cables with a cross-sectional area of at least 4mm² should be used, which are UV-resistant and have a temperature rating of 90°C.

Under load current, the cable connector must not be plugged in or unplugged.

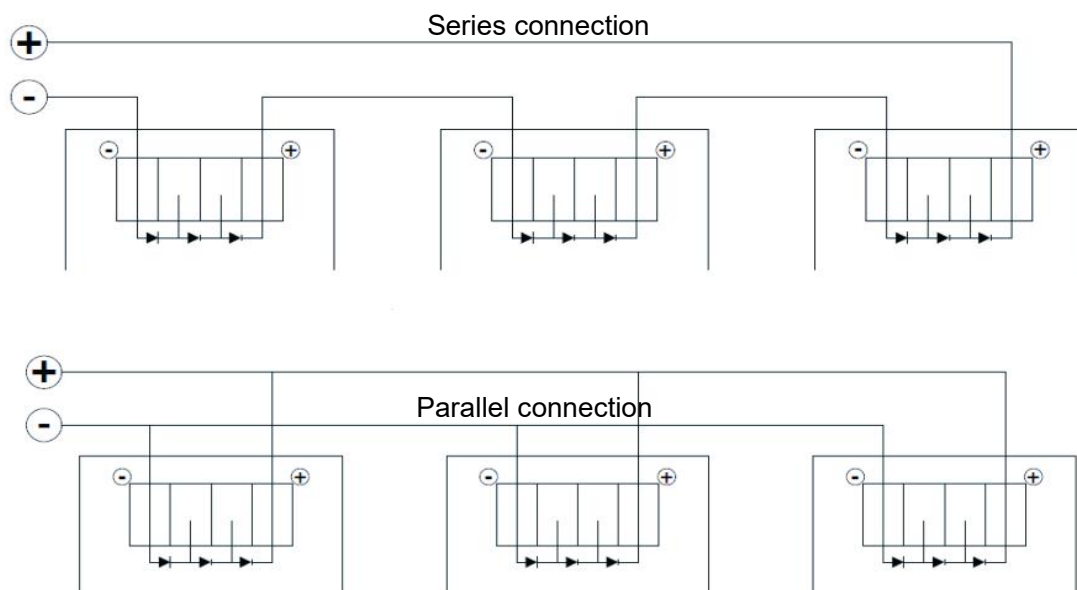

Figure 3: Wiring method

The cable of the junction box is defined as L1, as showed below. For Green Energy Power standard module, L1 is 300/1200mm; and for customized module, L1 can be based on your condition, take the cable length into consideration before designing the wiring layout.



Figure 4: Junction box

The Suppliers and types of connectors should be in accordance with the Standard IEC 62852. For more details, please see below:

	Manufacturer	Type / model
Junction box combination 1:		
Junction box	Zhejiang Zhonghuan Sunter PV Technology Co., Ltd.	Type: PV-ZH011C-5 Rated voltage= DC 1500V Rated current=25/30A Reverse current=30A
Connector 1	Zhejiang Zhonghuan Sunter PV Technology Co., Ltd.	PV-ZH202B Rated voltage= DC 1500V Rated current=30A
Junction box combination 2:		
Junction box	Zerun Co.,Ltd.	Type:Z8C Rated voltage =1500VDC Ratedcurrent=20/25/30A

Connector 1	Zerun Co.,Ltd.	Z4S-abcde (a=C or P; b=T or H; C=A or Bor C; d=A or B) 1500VDC for (d=B); 41Afor(c=B)
Connector 2	Stäubli Electrical Connectors AG	PV-KST4-EVO2/xy_UR (male);PV-KBT4-EVO2/xy_UR (female) Max. voltage [V]: 1500 Max. current [A]:45
Junction box combination 3:		
Junction box	Zhejiang Jiaming Tianheyuan Photovoltaics Technology Co., Ltd.	Type: JM07w Rated voltage=1500VDC Rated current= 20/25/30A Reverse current=41A
Connector 1	Zhejiang Jiaming Tianheyuan Photovoltaics Technology Co., Ltd.	JM-608 Max. Voltage=1500VDC Max. Current=41A
Connector 2	Stäubli Electrical Connectors AG	PV-KST4-EVO2/xy_UR (male);PV-KBT4-EVO2/xy_UR (female) Max. voltage [V]:1500 Max. current [A]:45
Junction box combination 4:		
Junction box	Zhejiang Jiaming Tianheyuan Photovoltaics Technology Co., Ltd.	Type: JM37xy (x=blank or 1) Rated voltage=1500VDC Rated current=25/30A Reverse current=41A
Connector 1	Zhejiang Jiaming Tianheyuan Photovoltaics Technology Co., Ltd.	JM-608 Max. Voltage=1500VDC Max. Current=41A
Connector 2	Stäubli Electrical Connectors AG	PV-KST4-EVO2/xy_UR (male);PV-KBT4-EVO2/xy_UR (female) Max. voltage [V]:1500 Max. current [A]:45

3.3.2 Module grounding

This is the grounding guide for module frames: If there is a grounding requirement, please ensure that the module (in contact with the metal) has been successfully grounded. The installation, wiring and grounding methods should be determined in accordance with national, regional and local norms, standards and laws, etc.

Each module has a pre-grounding hole in its usage frame. The correct grounding method is to connect the module frame to the other end with all the metal structural parts by using an appropriate grounding conductor. This kind of grounding wire should be made of copper, copper alloys or other suitable materials. The grounding conductor must be connected to the soil using an appropriate grounding electrode. Use the following method to ensure that the positive electrode is connected to the module frame without scratching the oxide film on the frame, as

shown in Figure 5.

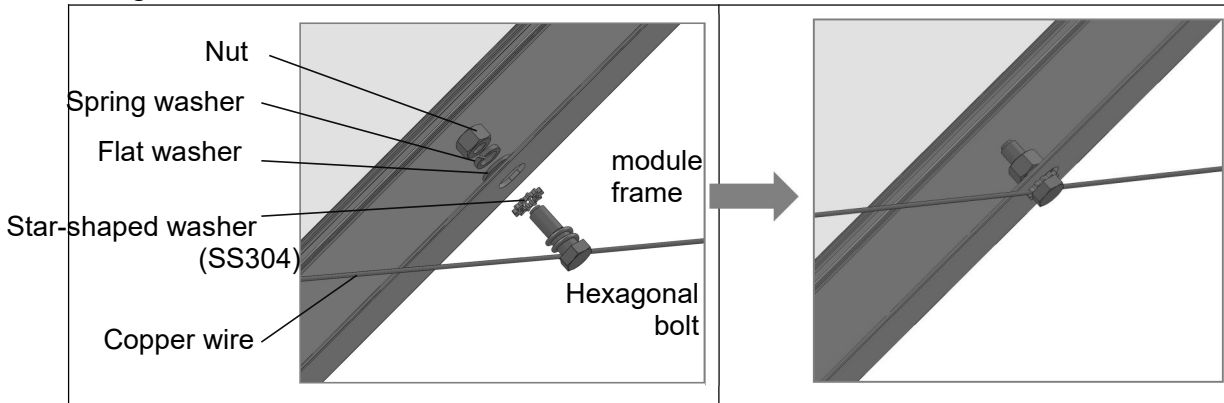

Figure 5: Grounding method

4. Inverter anti-module PID effect

For safety reasons, the aluminum frame will be grounded. There is a certain reverse potential difference between the internal circuit and the frame of the modules at the negative end of each string array. This potential difference will cause sodium ions in the glass to migrate to the battery cells, resulting in power attenuation of the modules, which is the PID effect. The inverter must be equipped with effective devices to prevent the occurrence of PID effects. Our company recommends the following two solutions:

Method 1: Ground the negative terminal of the PV directly or indirectly;

Method 2: Apply a DC bias to the PV negative electrode or the equivalent point to raise the potential of the PV negative electrode to ground.

5. Maintenance

The module design has a long service life and requires almost no maintenance measures. However, to ensure the best output of the module, we recommend the following checkpoints and some tasks during the module's operation.

- In cases of excessive contamination (such as dust or bird droppings), clean the glass surface of the modules with clean water and a soft cloth or non-abrasive sponge. Non-corrosive cleaners, acids or filters can remove stubborn dirt. When cleaning the back of the single-glass module, be extremely careful not to damage the back plate and the junction box/

- Electrical, mechanical and grounding connections must be inspected every six months to ensure they are clean, undamaged and free from corrosion.

- Check the installed hardware at least once a year to ensure sealing, as loose connections may cause module damage.

6. Others

Meaning of crossed – out wheeled dustbin:

Do not dispose of electrical appliances as unsorted municipal waste, use separate collection facilities. Contact your local government for information regarding the collection systems available. If electrical appliances are disposed of in landfills or dumps, hazardous substances can leak into the groundwater and get into the food chain, damaging your health and well-being.

When replacing old appliances with new ones, the retailer is legally obligated to take back your old appliance for disposals at least free of charge.

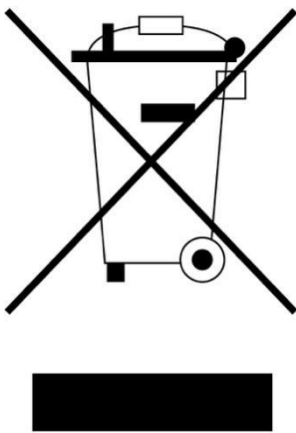

7. Electrical parameters

The information in this manual is based on Green Energy Power's knowledge and experience and is believed to be reliable, but such information including product specification (without limitations) and suggestions do not constitute a warranty, expresses or implied. Green Energy Power reserves the right to change the installation manual, the PV product, the electrical specifications, or product information sheets without prior notice. All electrical data should be measured under below test conditions:

STC: AM= 1.5, E= 1000 W/m², T_c=25 °C;

The additional test conditions for Bifacial PV modules:

BNPI: E= 1000 W/m² + φ•135 W/m²

BSI: E= 1000 W/m² + φ•300 W/m²

Pmax of any individual module will be within $\pm 3\%$ tolerance of these specified values.

Voc of any individual module will be within $\pm 3\%$ tolerance of these specified values.

Isc of any individual module will be within $\pm 3\%$ tolerance of these specified values.

Information in this document is subject to change without notice.

Model	Maximum power output (Pmax)	Optimum operation voltage (Vmp)	Optimum operation current (Imp)	Open circuit voltage (Voc)	Short circuit current (Isc)	Maximum system voltage (IEC)	Maximum series fuse rating (A)
GEP-IfMc XXXMH	385	30.55	12.61	36.45 \pm 3%	12.81 \pm 3%	1500	25
	390	30.79	12.67	36.69 \pm 3%	12.87 \pm 3%	1500	25
	395	31.03	12.73	36.93 \pm 3%	12.93 \pm 3%	1500	25
	400	31.28	12.79	37.18 \pm 3%	12.99 \pm 3%	1500	25
	405	31.52	12.85	37.42 \pm 3%	13.05 \pm 3%	1500	25
	410	31.76	12.91	37.67 \pm 3%	13.11 \pm 3%	1500	25
	415	32.00	12.97	37.92 \pm 3%	13.17 \pm 3%	1500	25
	420	32.24	13.03	38.17 \pm 3%	13.23 \pm 3%	1500	25
GEP-IfMc XXXMHB	385	30.55	12.61	36.45 \pm 3%	12.81 \pm 3%	1500	25
	390	30.79	12.67	36.69 \pm 3%	12.87 \pm 3%	1500	25
	395	31.03	12.73	36.93 \pm 3%	12.93 \pm 3%	1500	25
	400	31.28	12.79	37.18 \pm 3%	12.99 \pm 3%	1500	25
	405	31.52	12.85	37.42 \pm 3%	13.05 \pm 3%	1500	25
	410	31.76	12.91	37.67 \pm 3%	13.11 \pm 3%	1500	25
	415	32.00	12.97	37.92 \pm 3%	13.17 \pm 3%	1500	25
	420	32.24	13.03	38.17 \pm 3%	13.23 \pm 3%	1500	25
GEP-IfMc XXXMHT	385	30.55	12.61	36.45 \pm 3%	12.81 \pm 3%	1500	30
	390	30.79	12.67	36.69 \pm 3%	12.87 \pm 3%	1500	30
	395	31.03	12.73	36.93 \pm 3%	12.93 \pm 3%	1500	30
	400	31.28	12.79	37.18 \pm 3%	12.99 \pm 3%	1500	30
	405	31.52	12.85	37.42 \pm 3%	13.05 \pm 3%	1500	30
	410	31.76	12.91	37.67 \pm 3%	13.11 \pm 3%	1500	30
	415	32.00	12.97	37.92 \pm 3%	13.17 \pm 3%	1500	30
	420	32.24	13.03	38.17 \pm 3%	13.23 \pm 3%	1500	25
GEP-BfMc XXXMH	430	34.27	12.56	41.07 \pm 3%	12.76 \pm 3%	1500	25
	435	34.49	12.62	41.29 \pm 3%	12.82 \pm 3%	1500	25

	440	34.71	12.68	41.51 ± 3%	12.88 ± 3%	1500	25
	445	34.93	12.74	41.73 ± 3%	12.94 ± 3%	1500	25
	450	35.16	12.80	41.96 ± 3%	13.00 ± 3%	1500	25
	455	35.39	12.86	42.19 ± 3%	13.06 ± 3%	1500	25
	460	35.61	12.92	42.41 ± 3%	13.12 ± 3%	1500	25
	465	35.83	12.98	42.63 ± 3%	13.18 ± 3%	1500	25
GEP-BfMc XXXMHB	430	34.27	12.56	41.07 ± 3%	12.76 ± 3%	1500	25
	435	34.49	12.62	41.29 ± 3%	12.82 ± 3%	1500	25
	440	34.71	12.68	41.51 ± 3%	12.88 ± 3%	1500	25
	445	34.93	12.74	41.73 ± 3%	12.94 ± 3%	1500	25
	450	35.16	12.80	41.96 ± 3%	13.00 ± 3%	1500	25
	455	35.39	12.86	42.19 ± 3%	13.06 ± 3%	1500	25
	460	35.61	12.92	42.41 ± 3%	13.12 ± 3%	1500	25
GEP-BfMc XXXMHT	430	34.27	12.56	41.07 ± 3%	12.76 ± 3%	1500	30
	435	34.49	12.62	41.29 ± 3%	12.82 ± 3%	1500	30
	440	34.71	12.68	41.51 ± 3%	12.88 ± 3%	1500	30
	445	34.93	12.74	41.73 ± 3%	12.94 ± 3%	1500	30
	450	35.16	12.80	41.96 ± 3%	13.00 ± 3%	1500	30
	455	35.39	12.86	42.19 ± 3%	13.06 ± 3%	1500	30
	460	35.61	12.92	42.41 ± 3%	13.12 ± 3%	1500	30
GEP-EfMc XXXMH	470	37.24	12.62	44.55 ± 3%	12.98 ± 3%	1500	25
	475	37.43	12.69	44.77 ± 3%	13.03 ± 3%	1500	25
	480	37.62	12.76	44.98 ± 3%	13.10 ± 3%	1500	25
	485	37.81	12.83	45.20 ± 3%	13.17 ± 3%	1500	25
	490	37.99	12.90	45.33 ± 3%	13.24 ± 3%	1500	25
	495	38.17	12.97	45.45 ± 3%	13.31 ± 3%	1500	25
	500	38.35	13.04	45.59 ± 3%	13.38 ± 3%	1500	25
	505	38.53	13.11	45.72 ± 3%	13.45 ± 3%	1500	25
	510	38.70	13.18	45.85 ± 3%	13.52 ± 3%	1500	25
GEP-EfMc XXXMHB	470	37.24	12.62	44.55 ± 3%	12.98 ± 3%	1500	25
	475	37.43	12.69	44.77 ± 3%	13.03 ± 3%	1500	25
	480	37.62	12.76	44.98 ± 3%	13.10 ± 3%	1500	25

	485	37.81	12.83	45.20 ± 3%	13.17 ± 3%	1500	25
	490	37.99	12.90	45.33 ± 3%	13.24 ± 3%	1500	25
	495	38.17	12.97	45.45 ± 3%	13.31 ± 3%	1500	25
	500	38.35	13.04	45.59 ± 3%	13.38 ± 3%	1500	25
	505	38.53	13.11	45.72 ± 3%	13.45 ± 3%	1500	25
	510	38.70	13.18	45.85 ± 3%	13.52 ± 3%	1500	25
GEP-EfMc XXXMHT	470	37.24	12.62	44.55 ± 3%	12.98 ± 3%	1500	30
	475	37.43	12.69	44.77 ± 3%	13.03 ± 3%	1500	30
	480	37.62	12.76	44.98 ± 3%	13.10 ± 3%	1500	30
	485	37.81	12.83	45.20 ± 3%	13.17 ± 3%	1500	30
	490	37.99	12.90	45.33 ± 3%	13.24 ± 3%	1500	30
	495	38.17	12.97	45.45 ± 3%	13.31 ± 3%	1500	30
	500	38.35	13.04	45.59 ± 3%	13.38 ± 3%	1500	30
	505	38.53	13.11	45.72 ± 3%	13.45 ± 3%	1500	30
	510	38.70	13.18	45.85 ± 3%	13.52 ± 3%	1500	30
GEP-AfMc XXXMH	515	40.89	12.60	48.75 ± 3%	12.95 ± 3%	1500	25
	520	41.05	12.67	48.90 ± 3%	13.02 ± 3%	1500	25
	525	41.21	12.74	49.05 ± 3%	13.09 ± 3%	1500	25
	530	41.35	12.82	49.20 ± 3%	13.16 ± 3%	1500	25
	535	41.50	12.90	49.35 ± 3%	13.23 ± 3%	1500	25
	540	41.65	12.97	49.50 ± 3%	13.30 ± 3%	1500	25
	545	41.80	13.04	49.65 ± 3%	13.37 ± 3%	1500	25
	550	41.95	13.11	49.80 ± 3%	13.44 ± 3%	1500	25
	555	42.10	13.18	49.95 ± 3%	13.51 ± 3%	1500	25
	560	42.25	13.26	50.10 ± 3%	13.58 ± 3%	1500	25
GEP-AfMc XXXMHB	515	40.89	12.60	48.75 ± 3%	12.95 ± 3%	1500	25
	520	41.05	12.67	48.90 ± 3%	13.02 ± 3%	1500	25
	525	41.21	12.74	49.05 ± 3%	13.09 ± 3%	1500	25
	530	41.35	12.82	49.20 ± 3%	13.16 ± 3%	1500	25
	535	41.50	12.90	49.35 ± 3%	13.23 ± 3%	1500	25
	540	41.65	12.97	49.50 ± 3%	13.30 ± 3%	1500	25
	545	41.80	13.04	49.65 ± 3%	13.37 ± 3%	1500	25
	550	41.95	13.11	49.80 ± 3%	13.44 ± 3%	1500	25
	555	42.10	13.18	49.95 ± 3%	13.51 ± 3%	1500	25
	560	42.25	13.26	50.10 ± 3%	13.58 ± 3%	1500	25
GEP-AfMc XXXMHT	515	40.89	12.60	48.75 ± 3%	12.95 ± 3%	1500	30

	520	41.05	12.67	48.90 ± 3%	13.02 ± 3%	1500	30
	525	41.21	12.74	49.05 ± 3%	13.09 ± 3%	1500	30
	530	41.35	12.82	49.20 ± 3%	13.16 ± 3%	1500	30
	535	41.50	12.90	49.35 ± 3%	13.23 ± 3%	1500	30
	540	41.65	12.97	49.50 ± 3%	13.30 ± 3%	1500	30
	545	41.80	13.04	49.65 ± 3%	13.37 ± 3%	1500	30
	550	41.95	13.11	49.80 ± 3%	13.44 ± 3%	1500	30
	555	42.10	13.18	49.95 ± 3%	13.51 ± 3%	1500	30
	560	42.25	13.26	50.10 ± 3%	13.58 ± 3%	1500	30
GEP-FfMc XXXMH	580	45.00	12.90	53.50 ± 3%	13.86 ± 3%	1500	25
	585	45.12	12.97	53.66 ± 3%	13.92 ± 3%	1500	25
	590	45.25	13.04	53.82 ± 3%	13.98 ± 3%	1500	25
	595	45.40	13.11	53.98 ± 3%	14.04 ± 3%	1500	25
	600	45.55	13.18	54.14 ± 3%	14.10 ± 3%	1500	25
	605	45.70	13.25	54.30 ± 3%	14.16 ± 3%	1500	25
	610	45.85	13.32	54.46 ± 3%	14.22 ± 3%	1500	25
GEP-FfMc XXXMHB	580	45.00	12.90	53.50 ± 3%	13.86 ± 3%	1500	25
	585	45.12	12.97	53.66 ± 3%	13.92 ± 3%	1500	25
	590	45.25	13.04	53.82 ± 3%	13.98 ± 3%	1500	25
	595	45.40	13.11	53.98 ± 3%	14.04 ± 3%	1500	25
	600	45.55	13.18	54.14 ± 3%	14.10 ± 3%	1500	25
	605	45.70	13.25	54.30 ± 3%	14.16 ± 3%	1500	25
	610	45.85	13.32	54.46 ± 3%	14.22 ± 3%	1500	25
GEP-FfMc XXXMHT	580	45.00	12.90	53.50 ± 3%	13.86 ± 3%	1500	30
	585	45.12	12.97	53.66 ± 3%	13.92 ± 3%	1500	30
	590	45.25	13.04	53.82 ± 3%	13.98 ± 3%	1500	30
	595	45.40	13.11	53.98 ± 3%	14.04 ± 3%	1500	30
	600	45.55	13.18	54.14 ± 3%	14.10 ± 3%	1500	30
	605	45.70	13.25	54.30 ± 3%	14.16 ± 3%	1500	30
	610	45.85	13.32	54.46 ± 3%	14.22 ± 3%	1500	30
GEP-IfMc XXXNH	415	32.30	12.85	39.02 ± 3%	13.94 ± 3%	1500	25
	420	32.54	12.91	39.14 ± 3%	14.00 ± 3%	1500	25
	425	32.80	12.97	39.25 ± 3%	14.08 ± 3%	1500	25
	430	33.06	13.03	39.36 ± 3%	14.16 ± 3%	1500	25
	435	33.28	13.09	39.47 ± 3%	14.22 ± 3%	1500	25
	440	33.50	13.15	39.59 ± 3%	14.28 ± 3%	1500	25

	445	33.72	13.21	39.70 ± 3%	14.34 ± 3%	1500	25
	450	33.92	13.27	39.81 ± 3%	14.40 ± 3%	1500	25
	455	34.12	13.34	39.92 ± 3%	14.46 ± 3%	1500	25
	460	34.32	13.41	40.03 ± 3%	14.52 ± 3%	1500	25
GEP-IfMc XXXNHB	415	32.30	12.85	39.02 ± 3%	13.94 ± 3%	1500	25
	420	32.54	12.91	39.14 ± 3%	14.00 ± 3%	1500	25
	425	32.80	12.97	39.25 ± 3%	14.08 ± 3%	1500	25
	430	33.06	13.03	39.36 ± 3%	14.16 ± 3%	1500	25
	435	33.28	13.09	39.47 ± 3%	14.22 ± 3%	1500	25
	440	33.50	13.15	39.59 ± 3%	14.28 ± 3%	1500	25
	445	33.72	13.21	39.70 ± 3%	14.34 ± 3%	1500	25
	450	33.92	13.27	39.81 ± 3%	14.40 ± 3%	1500	25
	455	34.12	13.34	39.92 ± 3%	14.46 ± 3%	1500	25
	460	34.32	13.41	40.03 ± 3%	14.52 ± 3%	1500	25
GEP-IfMc XXXNHT	415	32.30	12.85	39.02 ± 3%	13.94 ± 3%	1500	30
	420	32.54	12.91	39.14 ± 3%	14.00 ± 3%	1500	30
	425	32.80	12.97	39.25 ± 3%	14.08 ± 3%	1500	30
	430	33.06	13.03	39.36 ± 3%	14.16 ± 3%	1500	30
	435	33.28	13.09	39.47 ± 3%	14.22 ± 3%	1500	30
	440	33.50	13.15	39.59 ± 3%	14.28 ± 3%	1500	30
	445	33.72	13.21	39.70 ± 3%	14.34 ± 3%	1500	30
	450	33.92	13.27	39.81 ± 3%	14.40 ± 3%	1500	30
	455	34.12	13.34	39.92 ± 3%	14.46 ± 3%	1500	30
	460	34.32	13.41	40.03 ± 3%	14.52 ± 3%	1500	30
GEP-BfMc XXXNH	455	36.36	12.53	43.11 ± 3%	13.71 ± 3%	1500	25
	460	36.51	12.62	43.23 ± 3%	13.79 ± 3%	1500	25
	465	36.65	12.70	43.36 ± 3%	13.87 ± 3%	1500	25
	470	36.84	12.78	43.48 ± 3%	13.95 ± 3%	1500	25
	475	36.98	12.85	43.61 ± 3%	14.03 ± 3%	1500	25
	480	37.12	12.95	43.73 ± 3%	14.11 ± 3%	1500	25
	485	37.26	13.02	43.86 ± 3%	14.19 ± 3%	1500	25
	490	37.40	13.12	43.98 ± 3%	14.27 ± 3%	1500	25
	495	37.56	13.20	44.11 ± 3%	14.35 ± 3%	1500	25
	500	37.68	13.27	44.23 ± 3%	14.40 ± 3%	1500	25
	505	37.82	13.36	44.35 ± 3%	14.45 ± 3%	1500	25
	510	37.96	13.44	44.47 ± 3%	14.50 ± 3%	1500	25

GEP-BfMc XXXNHB	455	36.36	12.53	43.11 ± 3%	13.71 ± 3%	1500	25
	460	36.51	12.62	43.23 ± 3%	13.79 ± 3%	1500	25
	465	36.65	12.70	43.36 ± 3%	13.87 ± 3%	1500	25
	470	36.84	12.78	43.48 ± 3%	13.95 ± 3%	1500	25
	475	36.98	12.85	43.61 ± 3%	14.03 ± 3%	1500	25
	480	37.12	12.95	43.73 ± 3%	14.11 ± 3%	1500	25
	485	37.26	13.02	43.86 ± 3%	14.19 ± 3%	1500	25
	490	37.40	13.12	43.98 ± 3%	14.27 ± 3%	1500	25
	495	37.56	13.20	44.11 ± 3%	14.35 ± 3%	1500	25
	500	37.68	13.27	44.23 ± 3%	14.40 ± 3%	1500	25
	505	37.82	13.36	44.35 ± 3%	14.45 ± 3%	1500	25
	510	37.96	13.44	44.47 ± 3%	14.50 ± 3%	1500	25
GEP-BfMc XXXNHT	455	36.36	12.53	43.11 ± 3%	13.71 ± 3%	1500	30
	460	36.51	12.62	43.23 ± 3%	13.79 ± 3%	1500	30
	465	36.65	12.70	43.36 ± 3%	13.87 ± 3%	1500	30
	470	36.84	12.78	43.48 ± 3%	13.95 ± 3%	1500	30
	475	36.98	12.85	43.61 ± 3%	14.03 ± 3%	1500	30
	480	37.12	12.95	43.73 ± 3%	14.11 ± 3%	1500	30
	485	37.26	13.02	43.86 ± 3%	14.19 ± 3%	1500	30
	490	37.40	13.12	43.98 ± 3%	14.27 ± 3%	1500	30
	495	37.56	13.20	44.11 ± 3%	14.35 ± 3%	1500	30
	500	37.68	13.27	44.23 ± 3%	14.40 ± 3%	1500	30
	505	37.82	13.36	44.35 ± 3%	14.45 ± 3%	1500	30
	510	37.96	13.44	44.47 ± 3%	14.50 ± 3%	1500	30
GEP-EfMc XXXNH	510	40.32	12.65	47.56 ± 3%	14.00 ± 3%	1500	25
	515	40.49	12.72	47.69 ± 3%	14.05 ± 3%	1500	25
	520	40.62	12.81	47.83 ± 3%	14.10 ± 3%	1500	25
	525	40.75	12.90	47.97 ± 3%	14.15 ± 3%	1500	25
	530	40.90	12.99	48.11 ± 3%	14.20 ± 3%	1500	25
	535	41.04	13.06	48.24 ± 3%	14.25 ± 3%	1500	25
	540	41.18	13.13	48.38 ± 3%	14.30 ± 3%	1500	25
	545	41.31	13.20	48.52 ± 3%	14.35 ± 3%	1500	25
	550	41.45	13.27	48.65 ± 3%	14.40 ± 3%	1500	25
	555	41.60	13.35	48.79 ± 3%	14.45 ± 3%	1500	25
	560	41.74	13.42	48.92 ± 3%	14.50 ± 3%	1500	25
GEP-EfMc XXXNHB	510	40.32	12.65	47.56 ± 3%	14.00 ± 3%	1500	25

	515	40.49	12.72	47.69 ± 3%	14.05 ± 3%	1500	25
	520	40.62	12.81	47.83 ± 3%	14.10 ± 3%	1500	25
	525	40.75	12.90	47.97 ± 3%	14.15 ± 3%	1500	25
	530	40.90	12.99	48.11 ± 3%	14.20 ± 3%	1500	25
	535	41.04	13.06	48.24 ± 3%	14.25 ± 3%	1500	25
	540	41.18	13.13	48.38 ± 3%	14.30 ± 3%	1500	25
	545	41.31	13.20	48.52 ± 3%	14.35 ± 3%	1500	25
	550	41.45	13.27	48.65 ± 3%	14.40 ± 3%	1500	25
	555	41.60	13.35	48.79 ± 3%	14.45 ± 3%	1500	25
	560	41.74	13.42	48.92 ± 3%	14.50 ± 3%	1500	25
GEP-EfMc XXXNHT	510	40.32	12.65	47.56 ± 3%	14.00 ± 3%	1500	30
	515	40.49	12.72	47.69 ± 3%	14.05 ± 3%	1500	30
	520	40.62	12.81	47.83 ± 3%	14.10 ± 3%	1500	30
	525	40.75	12.90	47.97 ± 3%	14.15 ± 3%	1500	30
	530	40.90	12.99	48.11 ± 3%	14.20 ± 3%	1500	30
	535	41.04	13.06	48.24 ± 3%	14.25 ± 3%	1500	30
	540	41.18	13.13	48.38 ± 3%	14.30 ± 3%	1500	30
	545	41.31	13.20	48.52 ± 3%	14.35 ± 3%	1500	30
	550	41.45	13.27	48.65 ± 3%	14.40 ± 3%	1500	30
	555	41.60	13.35	48.79 ± 3%	14.45 ± 3%	1500	30
GEP-AfMc XXXNH	550	43.81	12.57	51.58 ± 3%	13.80 ± 3%	1500	25
	555	43.95	12.64	51.73 ± 3%	13.86 ± 3%	1500	25
	560	44.09	12.72	51.88 ± 3%	13.92 ± 3%	1500	25
	565	44.23	12.79	52.03 ± 3%	13.98 ± 3%	1500	25
	570	44.37	12.86	52.18 ± 3%	14.04 ± 3%	1500	25
	575	44.51	12.92	52.33 ± 3%	14.10 ± 3%	1500	25
	580	44.65	13.01	52.48 ± 3%	14.16 ± 3%	1500	25
	585	44.79	13.08	52.63 ± 3%	14.22 ± 3%	1500	25
	590	44.93	13.15	52.78 ± 3%	14.28 ± 3%	1500	25
	595	45.07	13.21	52.93 ± 3%	14.34 ± 3%	1500	25
	600	45.22	13.27	53.08 ± 3%	14.40 ± 3%	1500	25
	605	45.37	13.34	53.22 ± 3%	14.46 ± 3%	1500	25
	610	45.52	13.40	53.37 ± 3%	14.52 ± 3%	1500	25
615	45.68	13.47	53.52 ± 3%	14.58 ± 3%	1500	25	
GEP-AfMc XXXNHB	550	43.81	12.57	51.58 ± 3%	13.80 ± 3%	1500	25

	555	43.95	12.64	51.73 ± 3%	13.86 ± 3%	1500	25
	560	44.09	12.72	51.88 ± 3%	13.92 ± 3%	1500	25
	565	44.23	12.79	52.03 ± 3%	13.98 ± 3%	1500	25
	570	44.37	12.86	52.18 ± 3%	14.04 ± 3%	1500	25
	575	44.51	12.92	52.33 ± 3%	14.10 ± 3%	1500	25
	580	44.65	13.01	52.48 ± 3%	14.16 ± 3%	1500	25
	585	44.79	13.08	52.63 ± 3%	14.22 ± 3%	1500	25
	590	44.93	13.15	52.78 ± 3%	14.28 ± 3%	1500	25
	595	45.07	13.21	52.93 ± 3%	14.34 ± 3%	1500	25
	600	45.22	13.27	53.08 ± 3%	14.40 ± 3%	1500	25
	605	45.37	13.34	53.22 ± 3%	14.46 ± 3%	1500	25
	610	45.52	13.40	53.37 ± 3%	14.52 ± 3%	1500	25
	615	45.68	13.47	53.52 ± 3%	14.58 ± 3%	1500	25
GEP-AfMc XXXNHT	550	43.81	12.57	51.58 ± 3%	13.80 ± 3%	1500	30
	555	43.95	12.64	51.73 ± 3%	13.86 ± 3%	1500	30
	560	44.09	12.72	51.88 ± 3%	13.92 ± 3%	1500	30
	565	44.23	12.79	52.03 ± 3%	13.98 ± 3%	1500	30
	570	44.37	12.86	52.18 ± 3%	14.04 ± 3%	1500	30
	575	44.51	12.92	52.33 ± 3%	14.10 ± 3%	1500	30
	580	44.65	13.01	52.48 ± 3%	14.16 ± 3%	1500	30
	585	44.79	13.08	52.63 ± 3%	14.22 ± 3%	1500	30
	590	44.93	13.15	52.78 ± 3%	14.28 ± 3%	1500	30
	595	45.07	13.21	52.93 ± 3%	14.34 ± 3%	1500	30
	600	45.22	13.27	53.08 ± 3%	14.40 ± 3%	1500	30
	605	45.37	13.34	53.22 ± 3%	14.46 ± 3%	1500	30
	610	45.52	13.40	53.37 ± 3%	14.52 ± 3%	1500	30
	615	45.68	13.47	53.52 ± 3%	14.58 ± 3%	1500	30
GEP-FfMc XXXNH	600	47.39	12.67	55.90 ± 3%	13.80 ± 3%	1500	25
	605	47.55	12.73	56.06 ± 3%	13.86 ± 3%	1500	25
	610	47.71	12.79	56.22 ± 3%	13.92 ± 3%	1500	25
	615	47.87	12.85	56.38 ± 3%	13.98 ± 3%	1500	25
	620	48.03	12.91	56.54 ± 3%	14.04 ± 3%	1500	25
	625	48.19	12.97	56.70 ± 3%	14.10 ± 3%	1500	25
	630	48.35	13.03	56.86 ± 3%	14.16 ± 3%	1500	25
	635	48.51	13.09	57.02 ± 3%	14.22 ± 3%	1500	25
	640	48.67	13.15	57.18 ± 3%	14.28 ± 3%	1500	25

	645	48.83	13.21	57.34 ± 3%	14.34 ± 3%	1500	25
	650	48.99	13.27	57.50 ± 3%	14.40 ± 3%	1500	25
	655	49.15	13.33	57.66 ± 3%	14.46 ± 3%	1500	25
	660	49.31	13.39	57.82 ± 3%	14.52 ± 3%	1500	25
	665	49.47	13.45	57.98 ± 3%	14.58 ± 3%	1500	25
GEP-FfMc XXXNHB	600	47.39	12.67	55.90 ± 3%	13.80 ± 3%	1500	25
	605	47.55	12.73	56.06 ± 3%	13.86 ± 3%	1500	25
	610	47.71	12.79	56.22 ± 3%	13.92 ± 3%	1500	25
	615	47.87	12.85	56.38 ± 3%	13.98 ± 3%	1500	25
	620	48.03	12.91	56.54 ± 3%	14.04 ± 3%	1500	25
	625	48.19	12.97	56.70 ± 3%	14.10 ± 3%	1500	25
	630	48.35	13.03	56.86 ± 3%	14.16 ± 3%	1500	25
	635	48.51	13.09	57.02 ± 3%	14.22 ± 3%	1500	25
	640	48.67	13.15	57.18 ± 3%	14.28 ± 3%	1500	25
	645	48.83	13.21	57.34 ± 3%	14.34 ± 3%	1500	25
	650	48.99	13.27	57.50 ± 3%	14.40 ± 3%	1500	25
	655	49.15	13.33	57.66 ± 3%	14.46 ± 3%	1500	25
	660	49.31	13.39	57.82 ± 3%	14.52 ± 3%	1500	25
665	49.47	13.45	57.98 ± 3%	14.58 ± 3%	1500	25	
GEP-FfMc XXXNHT	600	47.39	12.67	55.90 ± 3%	13.80 ± 3%	1500	30
	605	47.55	12.73	56.06 ± 3%	13.86 ± 3%	1500	30
	610	47.71	12.79	56.22 ± 3%	13.92 ± 3%	1500	30
	615	47.87	12.85	56.38 ± 3%	13.98 ± 3%	1500	30
	620	48.03	12.91	56.54 ± 3%	14.04 ± 3%	1500	30
	625	48.19	12.97	56.70 ± 3%	14.10 ± 3%	1500	30
	630	48.35	13.03	56.86 ± 3%	14.16 ± 3%	1500	30
	635	48.51	13.09	57.02 ± 3%	14.22 ± 3%	1500	30
	640	48.67	13.15	57.18 ± 3%	14.28 ± 3%	1500	30
	645	48.83	13.21	57.34 ± 3%	14.34 ± 3%	1500	30
	650	48.99	13.27	57.50 ± 3%	14.40 ± 3%	1500	30
	655	49.15	13.33	57.66 ± 3%	14.46 ± 3%	1500	30
	660	49.31	13.39	57.82 ± 3%	14.52 ± 3%	1500	30
665	49.47	13.45	57.98 ± 3%	14.58 ± 3%	1500	30	
GEP-BfMd XXXNH	605	35.59	17.00	42.30 ± 3%	18.32 ± 2%	1500	30
	610	35.80	17.04	42.50 ± 3%	18.36 ± 2%	1500	30
	615	36.01	17.08	42.70 ± 3%	18.40 ± 2%	1500	30

	620	36.22	17.12	42.90 ± 3%	18.44 ± 2%	1500	30
	625	36.43	17.16	43.10 ± 3%	18.48 ± 2%	1500	30
	630	36.64	17.20	43.30 ± 3%	18.52 ± 2%	1500	30
	635	36.85	17.24	43.50 ± 3%	18.56 ± 3%	1500	30
	640	37.06	17.27	43.70 ± 3%	18.60 ± 3%	1500	30
	645	37.27	17.31	43.90 ± 3%	18.64 ± 3%	1500	30
	650	37.48	17.35	44.10 ± 3%	18.68 ± 3%	1500	30
	655	37.69	17.38	44.30 ± 3%	18.72 ± 3%	1500	30
	660	37.90	17.42	44.50 ± 3%	18.76 ± 3%	1500	30
	665	38.11	17.46	44.70 ± 3%	18.80 ± 3%	1500	30
GEP-BfMd XXXNHB	605	35.59	17.00	42.30 ± 3%	18.32 ± 2%	1500	30
	610	35.80	17.04	42.50 ± 3%	18.36 ± 2%	1500	30
	615	36.01	17.08	42.70 ± 3%	18.40 ± 2%	1500	30
	620	36.22	17.12	42.90 ± 3%	18.44 ± 2%	1500	30
	625	36.43	17.16	43.10 ± 3%	18.48 ± 2%	1500	30
	630	36.64	17.20	43.30 ± 3%	18.52 ± 2%	1500	30
	635	36.85	17.24	43.50 ± 3%	18.56 ± 3%	1500	30
	640	37.06	17.27	43.70 ± 3%	18.60 ± 3%	1500	30
	645	37.27	17.31	43.90 ± 3%	18.64 ± 3%	1500	30
	650	37.48	17.35	44.10 ± 3%	18.68 ± 3%	1500	30
	655	37.69	17.38	44.30 ± 3%	18.72 ± 3%	1500	30
	660	37.90	17.42	44.50 ± 3%	18.76 ± 3%	1500	30
665	38.11	17.46	44.70 ± 3%	18.80 ± 3%	1500	30	
GEP-BfMd XXXNHT	605	35.59	17.00	42.30 ± 3%	18.32 ± 2%	1500	35
	610	35.80	17.04	42.50 ± 3%	18.36 ± 2%	1500	35
	615	36.01	17.08	42.70 ± 3%	18.40 ± 2%	1500	35
	620	36.22	17.12	42.90 ± 3%	18.44 ± 2%	1500	35
	625	36.43	17.16	43.10 ± 3%	18.48 ± 2%	1500	35
	630	36.64	17.20	43.30 ± 3%	18.52 ± 2%	1500	35
	635	36.85	17.24	43.50 ± 3%	18.56 ± 3%	1500	35
	640	37.06	17.27	43.70 ± 3%	18.60 ± 3%	1500	35
	645	37.27	17.31	43.90 ± 3%	18.64 ± 3%	1500	35
	650	37.48	17.35	44.10 ± 3%	18.68 ± 3%	1500	35
	655	37.69	17.38	44.30 ± 3%	18.72 ± 3%	1500	35
	660	37.90	17.42	44.50 ± 3%	18.76 ± 3%	1500	35
665	38.11	17.46	44.70 ± 3%	18.80 ± 3%	1500	35	

GEP-EfMd XXXNH	660	38.85	17.00	46.10 ± 3%	18.32 ± 3%	1500	30
	665	39.05	17.04	46.30 ± 3%	18.36 ± 3%	1500	30
	670	39.25	17.08	46.50 ± 3%	18.40 ± 3%	1500	30
	675	39.45	17.12	46.70 ± 3%	18.44 ± 3%	1500	30
	680	39.65	17.16	46.90 ± 3%	18.48 ± 3%	1500	30
	685	39.86	17.19	47.10 ± 3%	18.52 ± 3%	1500	30
	690	40.06	17.23	47.30 ± 3%	18.57 ± 3%	1500	30
	695	40.27	17.26	47.50 ± 3%	18.61 ± 3%	1500	30
	700	40.48	17.30	47.70 ± 3%	18.65 ± 3%	1500	30
	705	40.69	17.33	47.90 ± 3%	18.69 ± 3%	1500	30
	710	40.90	17.36	48.10 ± 3%	18.73 ± 3%	1500	30
	715	41.11	17.40	48.30 ± 3%	18.77 ± 3%	1500	30
	720	41.32	17.43	48.50 ± 3%	18.81 ± 3%	1500	30
	725	41.53	17.46	48.70 ± 3%	18.85 ± 3%	1500	30
	730	41.74	17.50	48.90 ± 3%	18.89 ± 3%	1500	30
735	41.95	17.53	49.10 ± 3%	18.93 ± 3%	1500	30	
GEP-EfMd XXXNH	660	38.85	17.00	46.10 ± 3%	18.32 ± 3%	1500	30
	665	39.05	17.04	46.30 ± 3%	18.36 ± 3%	1500	30
	670	39.25	17.08	46.50 ± 3%	18.40 ± 3%	1500	30
	675	39.45	17.12	46.70 ± 3%	18.44 ± 3%	1500	30
	680	39.65	17.16	46.90 ± 3%	18.48 ± 3%	1500	30
	685	39.86	17.19	47.10 ± 3%	18.52 ± 3%	1500	30
	690	40.06	17.23	47.30 ± 3%	18.57 ± 3%	1500	30
	695	40.27	17.26	47.50 ± 3%	18.61 ± 3%	1500	30
	700	40.48	17.30	47.70 ± 3%	18.65 ± 3%	1500	30
	705	40.69	17.33	47.90 ± 3%	18.69 ± 3%	1500	30
	710	40.90	17.36	48.10 ± 3%	18.73 ± 3%	1500	30
	715	41.11	17.40	48.30 ± 3%	18.77 ± 3%	1500	30
	720	41.32	17.43	48.50 ± 3%	18.81 ± 3%	1500	30
	725	41.53	17.46	48.70 ± 3%	18.85 ± 3%	1500	30
	730	41.74	17.50	48.90 ± 3%	18.89 ± 3%	1500	30
735	41.95	17.53	49.10 ± 3%	18.93 ± 3%	1500	30	
GEP-EfMd XXXNHT	660	38.85	17.00	46.10 ± 3%	18.32 ± 3%	1500	35
	665	39.05	17.04	46.30 ± 3%	18.36 ± 3%	1500	35
	670	39.25	17.08	46.50 ± 3%	18.40 ± 3%	1500	35
	675	39.45	17.12	46.70 ± 3%	18.44 ± 3%	1500	35

	680	39.65	17.16	46.90 ± 3%	18.48 ± 3%	1500	35
	685	39.86	17.19	47.10 ± 3%	18.52 ± 3%	1500	35
	690	40.06	17.23	47.30 ± 3%	18.57 ± 3%	1500	35
	695	40.27	17.26	47.50 ± 3%	18.61 ± 3%	1500	35
	700	40.48	17.30	47.70 ± 3%	18.65 ± 3%	1500	35
	705	40.69	17.33	47.90 ± 3%	18.69 ± 3%	1500	35
	710	40.90	17.36	48.10 ± 3%	18.73 ± 3%	1500	35
	715	41.11	17.40	48.30 ± 3%	18.77 ± 3%	1500	35
	720	41.32	17.43	48.50 ± 3%	18.81 ± 3%	1500	35
	725	41.53	17.46	48.70 ± 3%	18.85 ± 3%	1500	35
	730	41.74	17.50	48.90 ± 3%	18.89 ± 3%	1500	35
	735	41.95	17.53	49.10 ± 3%	18.93 ± 3%	1500	35
GEP-LfMr XXXNH	440	29.45	14.94	35.42 ± 3%	15.83 ± 3%	1500	30
	445	29.71	14.98	35.64 ± 3%	15.86 ± 3%	1500	30
	450	29.88	15.06	35.85 ± 3%	15.89 ± 3%	1500	30
	455	30.07	15.13	36.07 ± 3%	15.93 ± 3%	1500	30
	460	30.26	15.20	36.29 ± 3%	15.96 ± 3%	1500	30
GEP-IfMr XXXNH	480	32.49	14.78	39.11 ± 3%	15.72 ± 3%	1500	30
	485	32.73	14.82	39.35 ± 3%	15.76 ± 3%	1500	30
	490	32.97	14.87	39.60 ± 3%	15.80 ± 3%	1500	30
	495	33.14	14.94	39.85 ± 3%	15.83 ± 3%	1500	30
	500	33.38	14.98	40.09 ± 3%	15.86 ± 3%	1500	30
	505	33.55	15.06	40.34 ± 3%	15.89 ± 3%	1500	30
	510	33.71	15.13	40.58 ± 3%	15.92 ± 3%	1500	30
	515	33.87	15.21	40.82 ± 3%	15.95 ± 3%	1500	30
GEP-BfMr XXXNH	535	36.10	14.82	43.45 ± 3%	15.72 ± 3%	1500	30
	540	36.36	14.86	43.73 ± 3%	15.76 ± 3%	1500	30
	545	36.64	14.88	44.00 ± 3%	15.80 ± 3%	1500	30
	550	36.82	14.94	44.27 ± 3%	15.83 ± 3%	1500	30
	555	37.09	14.97	44.55 ± 3%	15.86 ± 3%	1500	30
	560	37.27	15.03	44.82 ± 3%	15.89 ± 3%	1500	30
	565	37.45	15.09	45.09 ± 3%	15.92 ± 3%	1500	30
	570	37.63	15.15	45.36 ± 3%	15.95 ± 3%	1500	30
GEP-EfMr XXXNH	590	39.71	14.86	47.80 ± 3%	15.72 ± 3%	1500	30
	595	40.00	14.88	48.10 ± 3%	15.76 ± 3%	1500	30
	600	40.30	14.90	48.40 ± 3%	15.80 ± 3%	1500	30

	605	40.50	14.94	48.70 ± 3%	15.83 ± 3%	1500	30
	610	40.80	14.96	49.00 ± 3%	15.86 ± 3%	1500	30
	615	41.00	15.00	49.30 ± 3%	15.89 ± 3%	1500	30
	620	41.20	15.05	49.60 ± 3%	15.92 ± 3%	1500	30
	625	41.40	15.10	49.90 ± 3%	15.95 ± 3%	1500	30
	630	41.60	15.15	50.20 ± 3%	15.98 ± 3%	1500	30
GEP-LfMc XXXBH	455	29.91	15.23	35.64 ± 3%	16.41 ± 3%	1500	25
	460	30.05	15.32	35.71 ± 3%	16.48 ± 3%	1500	25
	465	30.22	15.40	35.78 ± 3%	16.55 ± 3%	1500	25
	470	30.37	15.48	35.85 ± 3%	16.62 ± 3%	1500	25
	475	30.54	15.56	35.93 ± 3%	16.69 ± 3%	1500	25
	480	30.69	15.65	36.00 ± 3%	16.76 ± 3%	1500	25
	485	30.84	15.73	36.07 ± 3%	16.83 ± 3%	1500	25
GEP-IfMc XXXBH	515	33.84	15.23	40.09 ± 3%	16.41 ± 3%	1500	25
	520	33.96	15.32	40.17 ± 3%	16.48 ± 3%	1500	25
	525	34.10	15.40	40.25 ± 3%	16.55 ± 3%	1500	25
	530	34.26	15.48	40.34 ± 3%	16.62 ± 3%	1500	25
	535	34.41	15.56	40.42 ± 3%	16.69 ± 3%	1500	25
	540	34.53	15.65	40.50 ± 3%	16.76 ± 3%	1500	25
	545	34.67	15.73	40.58 ± 3%	16.83 ± 3%	1500	25
GEP-BfMc XXXBH	575	37.77	15.23	44.55 ± 3%	16.41 ± 3%	1500	25
	580	37.87	15.32	44.64 ± 3%	16.48 ± 3%	1500	25
	585	37.99	15.40	44.73 ± 3%	16.55 ± 3%	1500	25
	590	38.12	15.48	44.82 ± 3%	16.62 ± 3%	1500	25
	595	38.27	15.56	44.91 ± 3%	16.69 ± 3%	1500	25
	600	38.36	15.65	45.00 ± 3%	16.76 ± 3%	1500	25
	605	38.48	15.73	45.09 ± 3%	16.83 ± 3%	1500	25
GEP-EfMc XXXBH	635	41.70	15.23	49.00 ± 3%	16.41 ± 3%	1500	25
	640	41.80	15.32	49.10 ± 3%	16.48 ± 3%	1500	25
	645	41.90	15.40	49.20 ± 3%	16.55 ± 3%	1500	25
	650	42.00	15.48	49.30 ± 3%	16.62 ± 3%	1500	25
	655	42.10	15.56	49.40 ± 3%	16.69 ± 3%	1500	25
	660	42.20	15.65	49.50 ± 3%	16.76 ± 3%	1500	25
	665	42.30	15.73	49.60 ± 3%	16.83 ± 3%	1500	25
GEP-IfMc XXXBH	470	33.30	14.12	40.28 ± 3%	14.88 ± 3%	1500	25
	475	33.48	14.20	40.35 ± 3%	14.94 ± 3%	1500	25

	480	33.65	14.27	40.43 ± 3%	15.00 ± 3%	1500	25
	485	33.83	14.35	40.50 ± 3%	15.06 ± 3%	1500	25
	490	33.97	14.43	40.58 ± 3%	15.12 ± 3%	1500	25
	495	34.13	14.51	40.65 ± 3%	15.18 ± 3%	1500	25
GEP-BfMc XXXBH	525	37.20	14.12	44.75 ± 3%	14.88 ± 3%	1500	25
	530	37.33	14.20	44.83 ± 3%	14.94 ± 3%	1500	25
	535	37.52	14.27	44.92 ± 3%	15.00 ± 3%	1500	25
	540	37.66	14.35	45.00 ± 3%	15.06 ± 3%	1500	25
	545	37.77	14.43	45.08 ± 3%	15.12 ± 3%	1500	25
	550	37.92	14.51	45.17 ± 3%	15.18 ± 3%	1500	25
GEP-EfMc XXXBH	580	41.10	14.12	49.23 ± 3%	14.88 ± 3%	1500	25
	585	41.22	14.20	49.32 ± 3%	14.94 ± 3%	1500	25
	590	41.35	14.27	49.41 ± 3%	15.00 ± 3%	1500	25
	595	41.49	14.35	49.50 ± 3%	15.06 ± 3%	1500	25
	600	41.59	14.43	49.59 ± 3%	15.12 ± 3%	1500	25
	605	41.71	14.51	49.68 ± 3%	15.18 ± 3%	1500	25
GEP-AfMc XXXBH	635	45.00	14.12	53.70 ± 3%	14.88 ± 3%	1500	25
	640	45.10	14.20	53.80 ± 3%	14.94 ± 3%	1500	25
	645	45.20	14.27	53.90 ± 3%	15.00 ± 3%	1500	25
	650	45.30	14.35	54.00 ± 3%	15.06 ± 3%	1500	25
	655	45.40	14.43	54.10 ± 3%	15.12 ± 3%	1500	25
	660	45.50	14.51	54.20 ± 3%	15.18 ± 3%	1500	25
GEP-IfMc XXXBH	440	33.20	13.27	40.34 ± 3%	14.03 ± 3%	1500	25
	445	33.37	13.35	40.42 ± 3%	14.11 ± 3%	1500	25
	450	33.51	13.44	40.49 ± 3%	14.20 ± 3%	1500	25
	455	33.69	13.52	40.57 ± 3%	14.28 ± 3%	1500	25
	460	33.85	13.60	40.64 ± 3%	14.36 ± 3%	1500	25
	465	34.00	13.68	40.72 ± 3%	14.44 ± 3%	1500	25
	470	34.15	13.78	40.79 ± 3%	14.52 ± 3%	1500	25
GEP-BfMc XXXBH	490	36.95	13.27	44.83 ± 3%	14.03 ± 3%	1500	25
	495	37.10	13.35	44.91 ± 3%	14.11 ± 3%	1500	25
	500	37.23	13.44	44.99 ± 3%	14.20 ± 3%	1500	25
	505	37.38	13.52	45.08 ± 3%	14.28 ± 3%	1500	25
	510	37.50	13.60	45.16 ± 3%	14.36 ± 3%	1500	25
	515	37.59	13.70	45.24 ± 3%	14.44 ± 3%	1500	25
	520	37.69	13.80	45.33 ± 3%	14.52 ± 3%	1500	25

GEP-EfMc XXXBH	540	40.71	13.27	49.31 ± 3%	14.03 ± 3%	1500	25
	545	40.84	13.35	49.40 ± 3%	14.11 ± 3%	1500	25
	550	40.95	13.44	49.49 ± 3%	14.20 ± 3%	1500	25
	555	41.10	13.52	49.58 ± 3%	14.28 ± 3%	1500	25
	560	41.20	13.60	49.67 ± 3%	14.36 ± 3%	1500	25
	565	41.29	13.69	49.77 ± 3%	14.44 ± 3%	1500	25
	570	41.41	13.77	49.86 ± 3%	14.52 ± 3%	1500	25
GEP-AfMc XXXBH	590	44.48	13.27	53.79 ± 3%	14.03 ± 3%	1500	25
	595	44.58	13.35	53.89 ± 3%	14.11 ± 3%	1500	25
	600	44.68	13.44	53.99 ± 3%	14.20 ± 3%	1500	25
	605	44.78	13.52	54.09 ± 3%	14.28 ± 3%	1500	25
	610	44.88	13.60	54.19 ± 3%	14.36 ± 3%	1500	25
	615	44.98	13.68	54.29 ± 3%	14.44 ± 3%	1500	25
	620	45.08	13.76	54.39 ± 3%	14.52 ± 3%	1500	25



绿能电力
GREEN ENERGY POWER

Jiangsu Green Energy Power Technology Co., Ltd;

No.1 Sun Road, Youfang Industrial Zone,

Yangzhong City, 212218 Jiangsu Province,

P.R. China

Fax No: 0511-88532992/+86-511-88532992

Service Line: 0511-88129618 /+86-511-8812961